

Operating Instructions for the Classic *Wimberley Head*TM (WH-100 & WH-101 w/ QR C-30 Clamp)

NOTE: Production of this product ceased in the Fall of 2006. We no longer have inventory of this model in our new product inventory. Please contact us for availability and pricing of replacement parts as it may take a day or so to prepare them for shipment. We still offer repair service for this product.

Overview

The Wimberley Head is unlike any other tripod head on the market. Setting up the Head is not difficult, but it is important to read these instructions because certain mistakes and misunderstandings are common.

The moving parts of the Head perform three functions, allowing you to 1) sweep the lens horizontally (pan), 2) tilt the lens vertically, and 3) adjust the height of the platform upon which the lens is mounted (fig. 2).

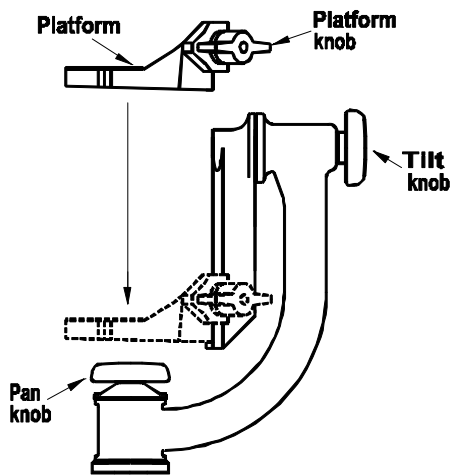

Figure 1

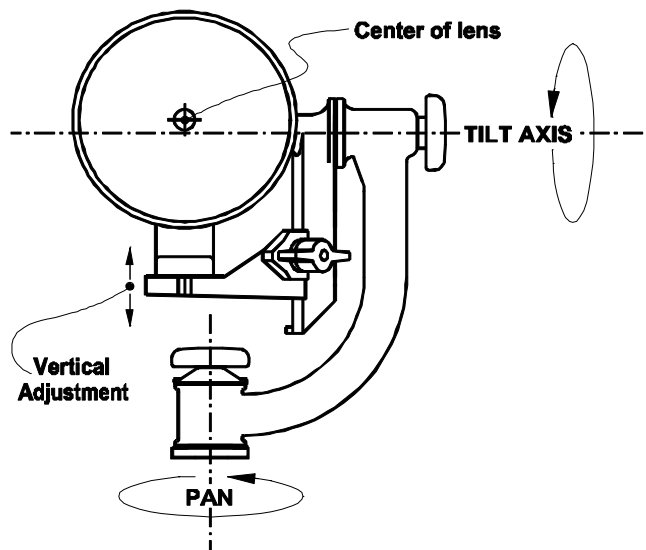

Figure 2

Setting Up:

The Wimberley Head comes with its platform detached so that it is more compact for shipping. To attach the platform to the Head, loosen the platform knob and slide the platform onto the swinging arm of the Head (Fig. 1). Slide the platform all the way down until it hits the stop at the bottom; then tighten the platform knob. You will be adjusting the height of the platform later. To mount the Head to a tripod, firmly tighten the lower (pan) knob. This allows you to screw the Head onto the 3/8" stud on top of your tripod. Seat the Head firmly onto the tripod.

Attaching Your Lens to the Wimberley Head:

For Wimberley Heads with C-30 QR Clamp installed (WH-101):

Lock the tilt knob of the Wimberley Head so that the Head is stable while you are loading your lens. Open the jaws of the quick-release clamp wide enough so that the jaws clear the entire width of the quick-release plate attached to the foot of your lens (If your lens does not have a quick-release plate attached, you can purchase one from us). Insert the quick-release plate on your lens into the jaws of the quick-release clamp and tighten the clamp securely. If you loosen the quick-release clamp, you can slide the lens forward or backward to adjust the balance the lens (see "Balancing Your Lens" below). Re-tighten the clamp after each adjustment.

For Non-Quick-Release Wimberley Heads (WH-100):

Three 1½" long threaded rods (studs) and three four-pronged knobs come with this Head for mounting your lens directly to the platform. Two of the stud/knob combinations are for 1/4" threads and one is for 3/8" threads. (Note: *The second ¼" fastener set is to be used for a second lens, or as a backup set if you should lose the first set. It is rarely possible to fit both ¼" fasteners into the foot of a lens with multiple mounting holes.*) Select the proper stud and knob for your lens, then screw the stud into the lens foot so that at least 5/8" of the stud is sticking out. The 1/4" stud comes with a plastic collar that keeps the stud centered in the platform slot. Thread the end with the collar into the lens foot. Note: *It is important that you screw the stud by itself into the foot of the lens first.* This insures that the stud is fully seated in the threaded hole of the lens foot. If you try to screw the stud and knob combination into the lens foot, the knob can spin without actually threading the stud into the lens foot. This can give you an inaccurate sense of how far you have screwed the stud into the lens foot.

Set the lens onto the platform with the stud in the platform slot. Fasten the lens to the Head platform with the appropriate knob.

The easiest way to keep track of your mounting hardware is to keep it attached to the foot of the lens when you are not using the Head.

Note: The slot should provide enough adjustment to achieve perfect fore-aft balance (See "Balancing Your Lens" below), but on occasion you may need more adjustment. If this is the case, you will need to purchase a quick-release clamp and lens plate from us.

Balancing Your Lens:

Your lens *with camera body attached* should be mounted to the Wimberley Head, and the Head's platform should be at its lowest position. Stand behind the lens/camera setup and grab the camera body as if you are going to take a picture. Loosen the tilt knob of the Wimberley Head. Upon loosening the knob, if the lens pitches forward, you will need to slide the lens toward you. If the lens pitches backwards, you will need to slide the lens away from you. Adjust the position of the lens until it does not pitch forward or backward.

Now that you've properly adjusted the forward-backward position of the lens, you must adjust the vertical position of the lens. Loosen the platform knob and adjust the vertical position of the lens so that the center of the lens is roughly aligned with the tilt axis of the head (fig. 2, previous page). Loosen the tilt knob and tilt the lens about 30 degrees toward the sky. When you let go of the lens, if it wants to keep going in the direction that you've tilted it, you need to lower the position of the lens by adjusting the position of the platform. If the lens wants to return to a level position, you need to raise the position of the lens.

The goal is to perfectly balance the lens so that it stays pointed in any position even when the Head is completely loose. Fine-tune the vertical and forward-backward position of the lens until you've achieved perfect balance. The Head is now ready to use. Simply loosen the pan and tilt knobs about a quarter-turn and start shooting. If you have done everything properly, the lens should be very easy to point, should stay pointed, and should not tend to flop or creep. As you become more familiar with the Head you will be better able to make fine adjustments in the balance of your setup. You can shoot with the knobs loose, or lock in on a target by tightening the knobs. If things don't feel right, please contact us.

Useful Add-Ons:

Wimberley Head Flash Bracket:

We offer a flash bracket that attaches directly to the Wimberley Head and makes telephoto flash a breeze (Old Wimberley Head Bracket, Part # F-4, \$186). The bracket uses a quick-release attachment so it is very fast and easy to install. It also folds for easy storage. Please refer to our catalog or web site for details.

Quick-Release System:

If you are not using a quick-release system on your Wimberley Head you can easily add one. We sell an Arca-Swiss style quick-release clamp specifically for the Wimberley Head (Quick-Release Clamp, Part # C-30, \$100) and a variety of lens plates. Different length Lens Plates are recommended for different lenses based on the length of plate necessary to achieve optimal balance and addition of a flash bracket to the plate. Please refer to our catalog or web site for details.

Tripod Levelers

Unless the top of the tripod is level, the horizon does not stay true as you pan. This is not a problem for most users who leave the rotation collar of their lens loose. Others would like a quick way to level the tripod. We sell 2 tripod levelers that solve this problem and are sturdy enough to support any size lens.

TL-502 (Manfrotto M-3502 Tripod Leveler)

This unit is about 2" high and mounts between the tripod head and any tripod.

TL-321 (Gitzo G1321 or G1520L Tripod Leveler)

This is the most elegant solution for those who have a pro-range (Studex) Gitzo tripod (Series 3 and up, excluding the 1326*). The Studex Gitzo tripods have an interchangeable center column or mounting platform that can be easily replaced with a leveling base.

Maintenance

If you disassemble the pan or tilt mechanism, refer to the assembly drawings provided at the end of these instructions for assembly. Instructions on refurbishing this Head are available upon request.

There should be almost no need for routine maintenance of the Head. It is constructed primarily of cast aluminum and stainless steel; corrosion should be an issue only for the radial roller thrust bearing assembly, which is part of the tilt mechanism. These components are not available in stainless steel. If, however, the Head gets contaminated with salt water or sand, for example, it can be easily disassembled and rinsed. If the Head simply gets rain soaked, it would be a good idea to dry the thrust bearing and lubricate it with oil or light grease. Note: *when removing the nut in the pan mechanism, use a 3/16 hex key to keep the stud from turning.*

Few things are likely to go wrong with the Wimberley Head. If the Head is in need of repair, you may order parts or return the Head for service. If a manufacturer defect arises, we will fix it free of cost. If the problem arises from normal wear with age, extreme use or abuse, or accident, we will repair the Head for a very reasonable fee.

Thank You

Your observations and suggestions are invited. We have continued to refine this Head in response to customer feedback, and we now have an updated and improved Wimberley Head Version II available. Please contact us if you are interested in upgrading your current Head to the latest version.

We wish you the best of luck using your Wimberley Head.

Wimberley, Inc.
974 Baker Lane
Winchester, VA 22603
USA

Phone: 540-665-2744, toll-free in US & Canada 1-888-665-2746
FAX: 540-665-2756
Email: info@tripodhead.com

www.tripodhead.com

